

P95 Trailer

The next generation
of mobile concrete mixers

FOR MORE DETAILS
+1 855.335.9500



P95 TRAILER MODEL

The P95 Trailer is a versatile and efficient concrete mixing machine that allows for on-site production, precise material measurements, and customizable batch sizes.

HIGHLIGHTED SPECIFICATIONS

Production Capacity	9.2m ³ / 12yd ³
Hourly Production Rate	70m ³ /90yd ³
Aggregate Bin	6.3m ³ / 221ft ³
Sand Bin	5.5m ³ / 193ft ³
Cement Bin	3.2m ³ / 113ft ³
Water Tank	3312L / 875gal

STANDARD FEATURES

Wireless Remote	Variable Speed Cement Metering
Two Automated Admix System	Automated Chain Oil
Batch Ticketing System	Aluminum Fenders
Automated Water System	Automated Electric Vibrators
High Efficiency Hydraulic Pump	Black Mesh Aggregate Tarp
Auxiliary Engine 100-140Hp Tier 4 or Complete Electric System	

ADDITIONAL OPTIONS

Body	Application
<input type="checkbox"/> Aggregate Bin Liner	<input type="checkbox"/> Additional Vibrators
<input type="checkbox"/> 360° Swivel Chute	<input type="checkbox"/> Color Feeder
<input type="checkbox"/> Aluminum Tool Box	<input type="checkbox"/> Fiber Feeder
<input type="checkbox"/> Aerator System for Cement Bin	<input type="checkbox"/> Gunite Auger
<input type="checkbox"/> Larger Cement Bin	<input type="checkbox"/> Heat Exchanger
<input type="checkbox"/> Pneumatic Fill	<input type="checkbox"/> Additional Admix Tanks
<input type="checkbox"/> Dual Water Tank Fill	
<input type="checkbox"/> Split Cement/Fly Ash Bin	Additional
	<input type="checkbox"/> Pressure Washer
Safety	<input type="checkbox"/> Custom Paint
<input type="checkbox"/> Standard System Rear Ladder & Platform	<input type="checkbox"/> Extra Oil Cooler
<input type="checkbox"/> Cement Bin Safety Rail	<input type="checkbox"/> Auto-Lube System
	<input type="checkbox"/> PTO and Installation of PTO
Verification	<input type="checkbox"/> Washout Kit
<input type="checkbox"/> Belt Materials Sensors	
<input type="checkbox"/> Gate Height	
Verification Sensors	
<input type="checkbox"/> Load Cell System	
<input type="checkbox"/> Low Level Cement Sensor	



Discover more about our options
and how they can improve your
businesses needs.

OUR ADVANTAGE



Accuracy

Our Commander automated control system ensures accurate and consistent concrete production.



Operator Design

Commander prioritizes operator ease, offering a user-friendly interface and intuitive controls for seamless operation.



Customer Support

ProAll offers reliable customer support, providing prompt assistance for any inquiries or technical issues.

GET IN TOUCH



Sales: 1.855.335.9500
Parts: 1.855.335.9500
Support: 1.833.577.6255



Sales: ProAll.Info@Terex.com
Parts: ProAll.Parts@Terex.com
Support: ProAll.Support@Terex.com



Visit: www.Proallinc.com



P95 TRAILER MODEL

The P95 Trailer is a versatile and efficient concrete mixing machine that allows for on-site production, precise material measurements, and customizable

Standard Features

Model	P95 Trailer
Product Capacity	9.2m ³ / 12yd ³
Production Rate	70m ³ /hr (90yd ³ / hr)
Cement Bin	3.2/3.8/5.2m ³ / 113/133/186ft ³
Water Tank	3312L /875 US gal
Aggregate Bin A	6.3m ³ / 221ft ³
Aggregates Bin B	5.5m ³ / 193ft ³
Admix Tank 1	40L / 10 gal
Admix Tank 2	80L / 20 gal
Mixing Auger Diameter/Length	(228mm) 9" / (2438mm) 96"
Operator Control	Console/ Wireless
Control System	Commander 2.0
Drive	Truck Connection Needed
Two Way Remote	On-board remote
Tarp Cover	Mesh
Delivery Printer	On-board printer
P95 Unit Length	9017mm / 355"
P95 Trailer Unit Height	3594.1mm / 141.5"
P95 Trailer Unit Working Swing	120 degree
P95 Trailer Unit Weight (dry weight)	*5897 kg / 13000 lbs
Chain Lubrication	Automated
Water System	Automated
Vibrators	Electric
Hydraulic Pumps	High Efficiency Pumps

* Depending on mounting configuration

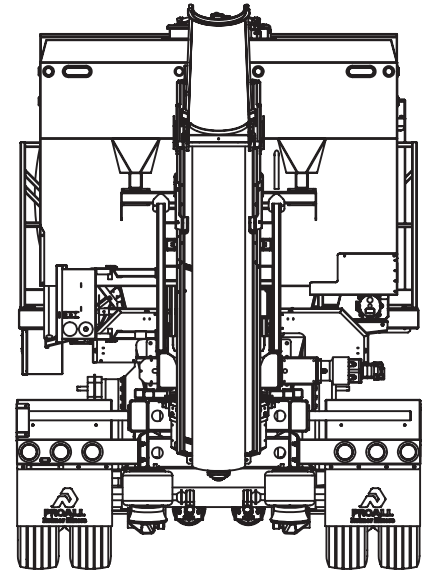

2590.8mm / 102"

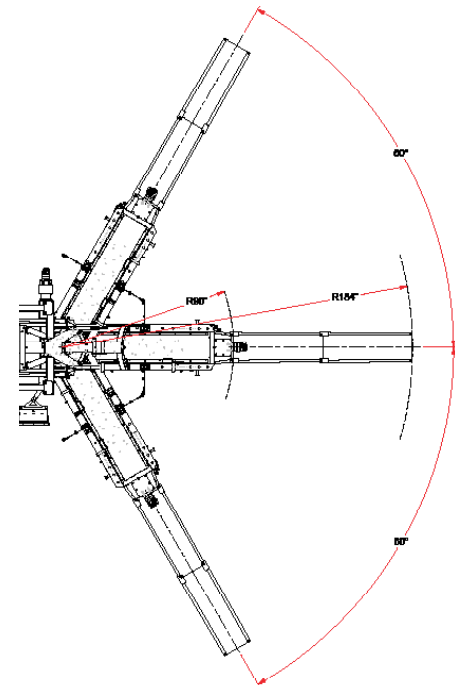

3594.1mm / 141.5"

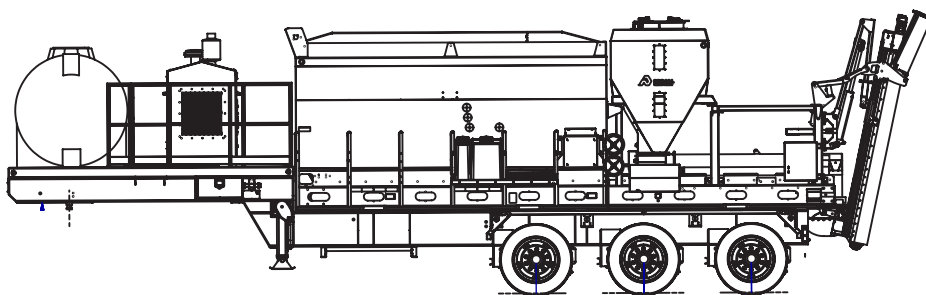

9017mm / 355"