



PROALL®
A TEREX BRAND

P95

the next generation
of mobile concrete mixers

FOR MORE DETAILS
+1 855.335.9500



P95 MODEL

The P95 is a versatile and efficient concrete mixing machine that allows for on-site production, precise material measurements, and customizable batch sizes.

ADDITIONAL OPTIONS

Body

- Aggregate Bin Liner
- 360° Swivel Chute
- Aluminum Tool Box
- Aerator System for Cement Bin
- Larger Cement Bin
- Pnuematic Fill
- Dual Water Tank Fill
- Split Cement/Fly Ash Bin

Safety

- Standard System Rear Ladder & Platform
- Cement Bin Saftey Rail

Verification

- Belt Materials Sensors
- Gate Height
- Verification Sensors
- Load Cell System
- Low Level Cement Sensor

Application

- Additional Vibrators
- Color Feeder
- Fiber Feeder
- Gunite Auger
- Heat Exchanger
- Additional Admix Tanks

Additional

- Pressure Washer
- Custom Paint
- Extra Oil Cooler
- Auto-Lube System
- PTO and Installation of PTO
- Washout Kit

HIGHLIGHTED SPECIFICATIONS

Production Capacity	9.2m ³ / 12yd ³
Hourly Production Rate	70m ³ /90yd ³
Aggregate Bin	6.3m ³ / 221ft ³
Sand Bin	5.5m ³ / 193ft ³
Cement Bin	3.2m ³ / 113ft ³
Water Tank	2250L / 600gal

STANDARD FEATURES

Wireless Remote	Variable Speed Cement Metering
Two Automated Admix System	Automated Chain Oil
Batch Ticketing System	Aluminum Fenders
Automated Water System	Automated Electric Vibrators
High Efficiency Hydraulic Pump	Black Mesh Aggregate Tarp

OUR ADVANTAGE



Accuracy

Our Commander automated control system ensures accurate and consistent concrete production.



Operator Design

Commander prioritizes operator ease, offering a user-friendly interface and intuitive controls for seamless operation.



Customer Support

ProAll offers reliable customer support, providing prompt assistance for any inquiries or technical issues.

GET IN TOUCH



Sales: 1.855.335.9500
Parts: 1.855.335.9500
Support: 1.833.577.6255



Sales: Proall.Info@Terex.com
Parts: Proall.Parts@Terex.com
Support: Proall.Support@Terex.com



Visit: www.Proallinc.com



Discover more about our options and how they can improve your businesses needs.



P95 MODEL

The P95 is a versatile and efficient concrete mixing machine that allows for on-site production, precise material measurements, and customizable batch sizes.

Standard Features

Model	P95
Product Capacity	9.2m ³ / 12yd ³
Production Rate	70m ³ /hr (90yd ³ / hr)
Cement Bin	3.2/3.6m ³ / 113/133ft ³
Water Tank	2250 L / 600 US gal
Aggregate Bin A	6.3m ³ / 221ft ³
Aggregates Bin B	5.5m ³ / 193ft ³
Admix Tank 1	40L / 10 gal
Admix Tank 2	80L / 20 gal
Mixing Auger Diameter/Length	(228mm) 9" / (2438mm) 96"
Operator Control	Console/ Wireless
Control System	Commander 2.0
Drive	By truck PTO
Two Way Remote	On-board remote
Tarp Cover	Mesh
Delivery Printer	On-board printer
P95 Unit Length	7696mm / 303"
P95 Unit Height	2463.8mm / 97"
P95 Unit Working Swing	120 degree
P95 Unit Weight (dry weight)	*5502 kg / 12123 lbs
Chain Lubrication	Automated
Water System	Automated
Vibrators	Electric
Hydraulic Pumps	High Efficiency Pumps

* depending on mounting configuration

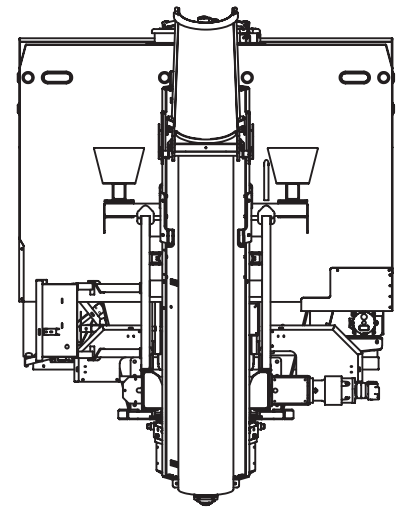

2294mm / 90 5/16"

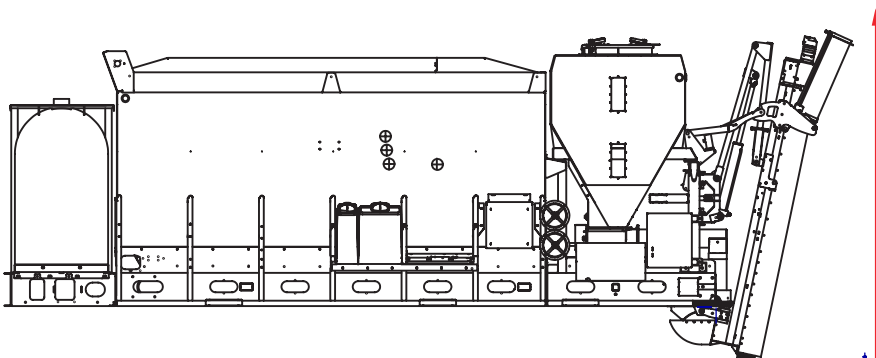

7696mm / 303"

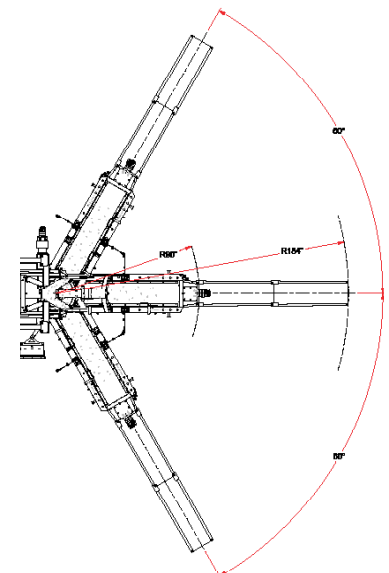

2463.8mm / 97"