



**PROALL**  
A TEREX BRAND

# P85

the next generation  
of mobile concrete mixers

FOR MORE DETAILS

+1 855.335.9500



## P85 MODEL

The P85 is a versatile and efficient concrete mixing machine that allows for on-site production, precise material measurements, and customizable batch sizes.

## ADDITIONAL OPTIONS

### Body

- Aggregate Bin Liner
- 360° Swivel Chute
- Aluminum Tool Box
- Aerator System for Cement Bin
- Larger Cement Bin
- Pneumatic Fill
- Dual Water Tank Fill
- Split Cement/Fly Ash Bin

### Safety

- Standard System Rear Ladder & Platform
- Cement Bin Safety Rail

### Verification

- Belt Materials Sensors
- Gate Height
- Verification Sensors
- Load Cell System
- Low Level Cement Sensor

### Application

- Additional Vibrators
- Color Feeder
- Fiber Feeder
- Heat Exchanger
- Additional Admix Tanks

### Additional

- Pressure Washer
- Custom Paint
- Extra Oil Cooler
- Auto-Lube System
- PTO and Installation of PTO
- Washout Kit

## HIGHLIGHTED SPECIFICATIONS

Production Capacity	7.6m <sup>3</sup> / 10yd <sup>3</sup>
Hourly Production Rate	70m <sup>3</sup> /90yd <sup>3</sup>
Aggregate Bin	5.2m <sup>3</sup> / 184ft <sup>3</sup>
Sand Bin	4.6m <sup>3</sup> / 161ft <sup>3</sup>
Cement Bin	3.2m <sup>3</sup> / 113ft <sup>3</sup>
Water Tank	2500L / 600gal

## STANDARD FEATURES

Wireless Remote	Variable Speed Cement Metering
Two Automated Admix System	Automated Chain Oil
Batch Ticketing System	Aluminum Fenders
Automated Water System	Automated Electric Vibrators
High Efficiency Hydraulic Pump	Black Mesh Aggregate Tarp

## ADVANTAGE



### Accuracy

Our Commander automated control system ensures accurate and consistent concrete production.



### Operator Design

Commander prioritizes operator ease, offering a user-friendly interface and intuitive controls for seamless operation.



### Customer Support

ProAll offers reliable customer support, providing prompt assistance for any inquiries or technical issues.

## GET IN TOUCH



Sales: 1.855.335.9500  
Parts: 1.855.335.9500  
Support: 1.833.577.6255



Sales: Proall.Info@Terex.com  
Parts: Proall.Parts@Terex.com  
Support: Proall.Support@Terex.com



Visit: [www.Proallinc.com](http://www.Proallinc.com)



Discover more about our options and how they can improve your businesses needs.



## P85 MODEL

The P85 is a versatile and efficient concrete mixing machine that allows for on-site production, precise material measurements, and customizable batch sizes.

### Standard Features

Model	P85
Product Capacity	7.6m <sup>3</sup> / 10yd <sup>3</sup>
Production Rate	70m <sup>3</sup> /hr (90yd <sup>3</sup> / hr)
Cement Bin	3.2m <sup>3</sup> / 113ft <sup>3</sup>
Water Tank	2500 L / 600 US gal
Aggregate Bin A	5.2m <sup>3</sup> / 184ft <sup>3</sup>
Aggregates Bin B	4.6m <sup>3</sup> / 161ft <sup>3</sup>
Admix Tank 1	40L / 10 gal
Admix Tank 2	80L / 20 gal
Mixing Auger Diameter/Length	(228mm) 9" / (2438mm) 96"
Operator Control	Console/ Wireless
Control System	Commander 2.0
Drive	By truck PTO
Two Way Remote	On-board remote
Tarp Cover	Mesh
Delivery Printer	On-board printer
P85 Unit Length	7696mm / 303"
P85 Unit Height	2456mm / 96 11/16"
P85 Unit Working Swing	120 degree
P85 Unit Weight (dry weight)	*5404 kg / 11913lbs
Chain Lubrication	Automated
Water System	Automated
Vibrators	Electric
Hydraulic Pumps	High Efficiency Pumps

\* Depending on mounting configuration

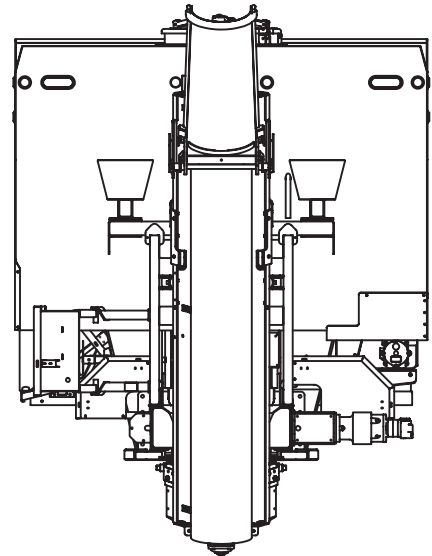

2294mm / 90 5/16"

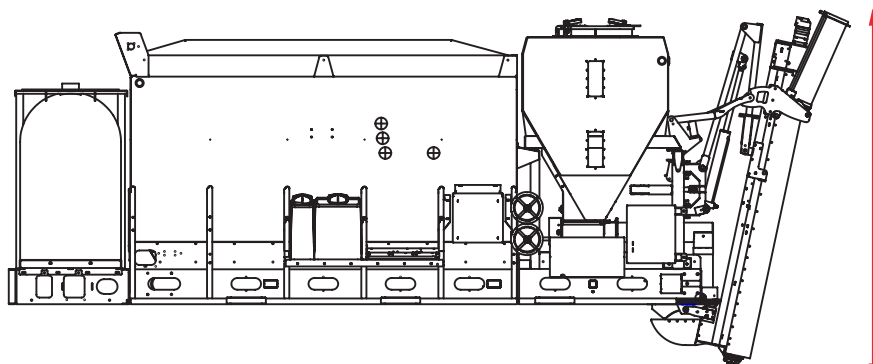
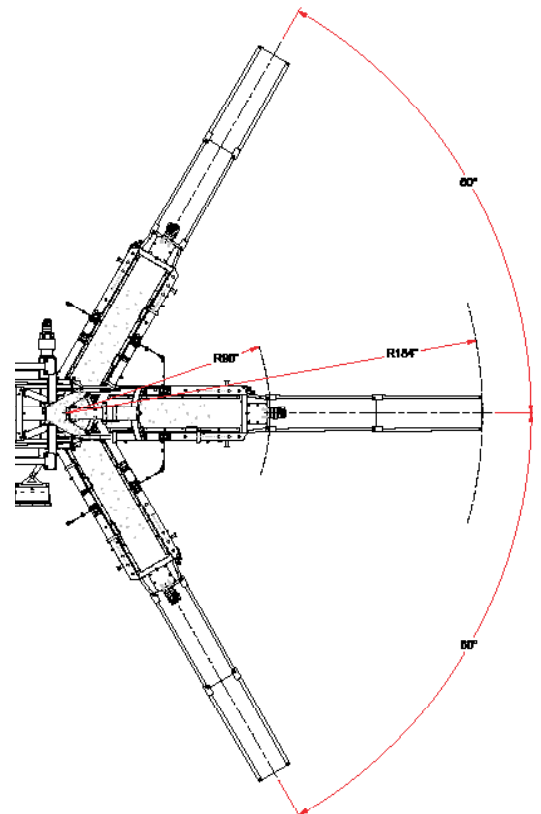

7696mm / 303"

2456mm / 96 11/16"