



**PROALL**  
A TEREX BRAND

# G95

the next generation  
of mobile concrete mixers

FOR MORE DETAILS

+1 855.335.9500

## G95 MODEL

The G95 Gunite Mixer from ProAll is quite simply the most advanced Gunite Mixer ever built. On board digital controls and cement speed verification ensure that you get the exact mix you require.



## ADDITIONAL OPTIONS

### Body

- Aggregate Bin Liner
- Aerator System for Cement Bin
- Aggregate Bin Extensions
- Pnuematic Fill with Filter Bag Assembly

### Safety

- Standard System Rear Ladder & Platform
- Cement Bin Saftey Rail

### Verification

- Belt Materials Sensors
- Gate Height
- Verification Sensors
- Load Cell System

### Additional

- Custom Paint
- Extra Oil Cooler

## HIGHLIGHTED SPECIFICATIONS

Product Capacity 12 yd<sup>3</sup> / 9.2m<sup>3</sup>  
 Production Rate 35 yd<sup>3</sup> / hr  
 Cement Bin 113ft<sup>3</sup>

## STANDARD FEATURES

Electronic Tarp System	Automated Chain Oil
Automated Water System	Automated Electric Vibrators
Variable Speed Cement Metering	Gunite Auger
	Auto-Lube System



Discover more about our options and how they can improve your businesses needs.

## OUR ADVANTAGE



### Accuracy

Our Rangercontrol system ensures accurate and consistent concrete production.



### Operator Design

Ranger prioritizes operator ease, offering a user-friendly interface and intuitive controls for seamless operation.



### Customer Support

ProAll offers reliable customer support, providing prompt assistance for any inquiries or technical issues.

## GET IN TOUCH



Sales: 1.855.335.9500  
 Parts: 1.855.335.9500  
 Support: 1.833.577.6255



Sales: Proall.Info@Terex.com  
 Parts: Proall.Support@Terex.com  
 Support: Proall.Parts@Terex.com



Visit: [www.Proallinc.com](http://www.Proallinc.com)



## G95 MODEL

The G95 Guniting Mixer from ProAll is quite simply the most advanced Guniting Mixer ever built. On board digital controls and cement speed verification ensure that you get the exact mix you require.

### Standard Features

Model	G95
Product Capacity	9.2m <sup>3</sup> / 12yd <sup>3</sup>
Production Rate	32m <sup>3</sup> /hr (35yd <sup>3</sup> / hr)
Cement Bin	3.2/3.8m <sup>3</sup> / 113/133ft <sup>3</sup>
Aggregate Bin A	11.7m <sup>3</sup> / 414ft <sup>3</sup>
Mixing Auger Diameter/Length	(228mm) 9"/ (2438mm) 96"
Operator Control	Console/ Wireless
Control System	Ranger
Drive	By truck PTO
Tarp Cover	Mesh
G95 Unit Length	6604mm / 260"
G95 Unit Height	2458mm / 97.5"
G95 Unit Weight (dry weight)	*5080 kg / 11200 lbs
Chain Lubrication	Automated
Vibrators	Electric
Hydraulic Pumps	High Efficiency Piston Pumps
Auto-Lube System	Auger Bearing and Seals

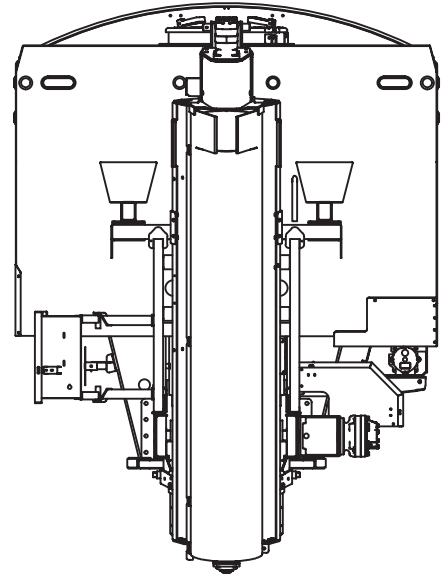

\* depending on mounting configuration

